

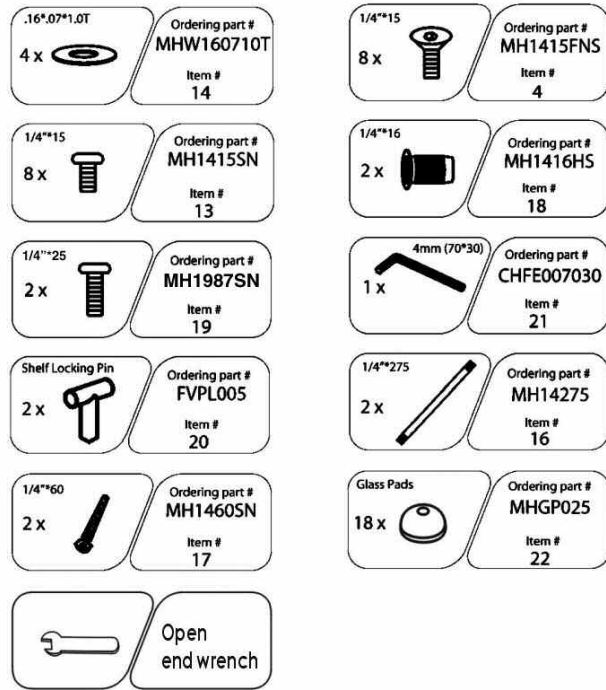

**Bell'O International, LLC**  
 711 Ginesi Drive  
 Morganville, NJ 07751-1235  
 Customer Service: (888) 235-7646  
 E-mail: support@bello.com  
 Web: www.bello.com

# AVS-2752HG

## ASSEMBLY INSTRUCTIONS



UNPACK ALL PARTS CAREFULLY SO THAT YOU DO NOT SCRATCH THE PARTS WHEN CUTTING THE STRAPPING OR TAPE DURING OPENING.

NOTE: TWO PEOPLE ARE RECOMMENDED TO ASSEMBLE THIS FURNITURE. IT SHOULD BE ASSEMBLED ON A SOFT, FLAT SURFACE.

A. PLACE the LOWER frame bars (1) and (2) UPSIDE DOWN on the floor so that the two holes in the bottom of the bars are facing upwards and the holes in the center of the sides of the bars are ALIGNED. NOTE THE DIRECTION OF THE SLANT AT THE BAR ENDS AS SHOWN IN FIG. 1 AND FIG. 2.

NOTE: The FRONT frame bars (1) and (5) have a hole in the rear side of the bar and NO HOLE in the front side of the bar. The REAR frame bars (2) and (6) have a hole that is goes completely through the bars. When positioned correctly, these holes will be ALIGNED when the front and rear frame bars are attached to each other.

B. ALIGN one of the two flat plates (3) with the upward facing holes in the two bottom frame bars, so that the recessed screw holes in the plate is also facing upwards, and SECURE the plate and the lower frame bars together with the 1/4" x 15 mm funnel neck screws (4).

C. REPEAT this assembly procedure for the UPPER frame bars (5) and (6). NOTE THE DIRECTION OF THE SLANT AT THE BAR ENDS AS SHOWN IN FIG. 1 AND FIG. 2.

D. TURN the BOTTOM frame bars (1) and (2) over so that the flat plate (3) is sitting on the floor.

NOTE: All four legs are the same. TO AVOID SCRATCHING the legs or the BOTTOM frame bars, CAREFULLY PLACE the four legs (7), (8), (9), and (10) upright with the slots in the bottom of each of the legs over the BOTTOM frame bar as shown in Fig. 1. The cut-out hole located on the middle side of each leg MUST be facing OUTWARD away from the center of the table when fully assembled. DO NOT SECURE THE LEGS TO THE BOTTOM FRAME BARS AT THIS POINT. This step is used to hold the furniture in place while securing the TOP frame bars.

E. TURN the attached TOP frame bars (5) and (6) over so that the flat plate (3) is facing downward towards the floor. TO AVOID SCRATCHING the legs or the TOP frame bars, CAREFULLY PLACE the TOP frame bars into the slots on top of the legs. SECURE the TOP frame bars to the legs with the 1/4" x 15 mm straight neck screws (13) and the supplied Allen key tool (21). LOOSELY SECURE THE SCREWS AT THIS POINT.

F. TO AVOID SCRATCHING THE FURNITURE, CAREFULLY LIFT the partially assembled table off of the BOTTOM frame bars (1) and (2), and CAREFULLY TURN the unit over so that it is resting on the TOP of the legs with the BOTTOM of the legs facing upwards. The TOP of the legs will already be attached to the TOP frame bars at this point.

G. TO AVOID SCRATCHING THE FURNITURE, CAREFULLY INSERT the CENTER shelf support bars (11) into the cutouts on the FRONT and REAR legs, with the curvature of bars facing OUTWARD as shown in Fig. 1.

NOTE: The REAR center shelf support bar (11) has two holes drilled in the outward curve of the bar's flat side. This bar should be facing the REAR of the furniture when fully assembled. This is the same direction as the holes in the REAR of the TOP and BOTTOM frame bars. The FRONT center shelf support bar (12) does NOT have any holes drilled in the bar's flat side.

H. CAREFULLY TURN the unit over so that it is resting on the BOTTOM of the legs again.

I. TO AVOID SCRATCHING THE FURNITURE, CAREFULLY PLACE the BOTTOM frame bars (1) and (2), into the open slots on the bottom of the legs with the flat plate (3) facing upwards. Make sure that the holes in the flat side of the BOTTOM frame bar are facing the REAR of the table when fully assembled. SECURE frame bars into the legs with the 1/4" x 15 mm straight neck screws (13) and the supplied Allen key tool (21).

J. NOW GO BACK AND TIGHTEN THE SCREWS THAT SECURE THE TOP AND BOTTOM FRAME BARS TO THE LEGS.

K. PLACE plastic caps (15) onto the top and bottom of the legs as shown in Fig. 2.

L. IDENTIFY the REAR of the furniture. The REAR of the TOP and BOTTOM frame bars have a hole drilled in the center of the bars where the FRONT and REAR frame bars meet.

M. Working from the REAR of the furniture, PLACE a washer (14) over the hole in the TOP frame bars. Using the supplied OPEN END WRENCH, SCREW the shorter threaded end of the LONG tie bar (16) through the REAR of the TOP frame bar and into the FRONT TOP frame bar until tight. REPEAT this tie bar (16) assembly for the BOTTOM frame bars.

NOTE: The open side of the CMS® (Cable Management System) frame (25) should be facing the rear of the table when fully assembled, and the two pre-drilled screw holes in the TOP of the CMS® frame should be facing upwards.

N. PLACE a washer (14) over the exposed ends of the LONG tie bars (16). CAREFULLY POSITION the CMS® frame (25) upright facing the exposed ends of the LONG tie bars (16).

O. ALIGN the front of the CMS® frame (25) with the exposed ends of the LONG tie bars (16) and SLIDE the CMS® frame onto the bars so that it is resting against the REAR center shelf support bar (11). From the REAR of the CMS® frame, INSERT the 1/4" x 60 mm screws (17) through the pre-drilled holes in the middle of the rear CMS® frame and SECURE to the REAR center shelf support bar using the supplied Allen key (21). DO NOT FULLY TIGHTEN AT THIS POINT.

P. SECURE the LONG tie bars (16) to the rear of the of the CMS® frame using 1/4" x 16 mm OPEN ended screws (18) and the Allen key (21).

Q. GO BACK and FULLY TIGHTEN the CMS® frame to the table frame.

R. MOVE the table to the location that it will occupy when fully assembled and in use.

S. PLACE glass support pads (22) onto the left, center and right tops of the BOTTOM frame bars, TOP frame bars and CENTER shelf support bars as shown in Fig. 1.

T. CAREFULLY POSITION and PLACE the TOP (largest) shelf (23) onto the TOP frame bars and top of the CMS® frame (25). Make sure that the two silver discs in the TOP shelf are facing the rear of the table and ALIGNED with and sit in the holes in the top of the CMS® frame. Working from the underside of the CMS® frame, SECURE the top shelf to the CMS® frame using the 1/4" x 25 mm screws (19) and the supplied Allen key (21).

U. CAREFULLY PLACE the two smaller shelves (24) onto the BOTTOM and CENTER shelf support frames with the holes in the shelves facing towards the REAR of the table, and INSERT the shelves through the cutout shelf slots in the CMS® frame. LOCK the shelves in place by INSERTING the T-shaped shelf locking pins (20) through the holes in the rear of the shelves.

IMPORTANT: REMOVE ALL GLASS, TV AND OTHER EQUIPMENT FROM THE FURNITURE PRIOR TO MOVING THE ASSEMBLED UNIT. DO NOT ATTEMPT TO MOVE THE ASSEMBLED FURNITURE AFTER THE GLASS SHELVES HAVE BEEN INSTALLED, AND/OR WHEN THERE IS EQUIPMENT LOCATED ON THE FURNITURE AS THIS MAY CAUSE THE SHELVES TO BECOME UNSECURED AND FALL. MAKE SURE THAT THE FRONT OF THE TV IS POSITIONED A FEW INCHES BACK FROM THE FRONT OF THE TOP GLASS. WHEN IN USE, THIS FURNITURE MUST BE PLACED ON A FLAT AND LEVEL SURFACE.

ALWAYS PLACE THE HEAVIEST EQUIPMENT ON THE BOTTOM SHELF.

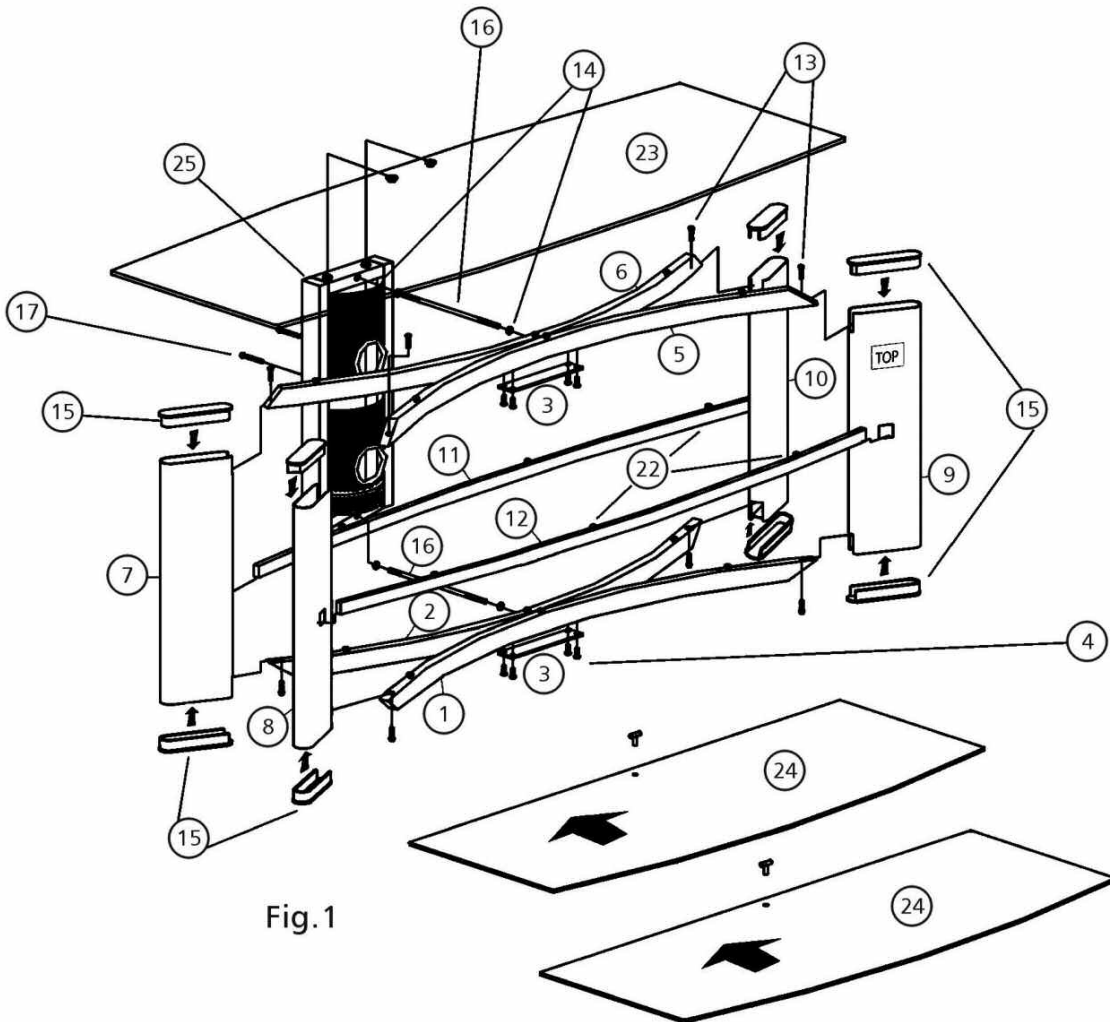

Fig. 1

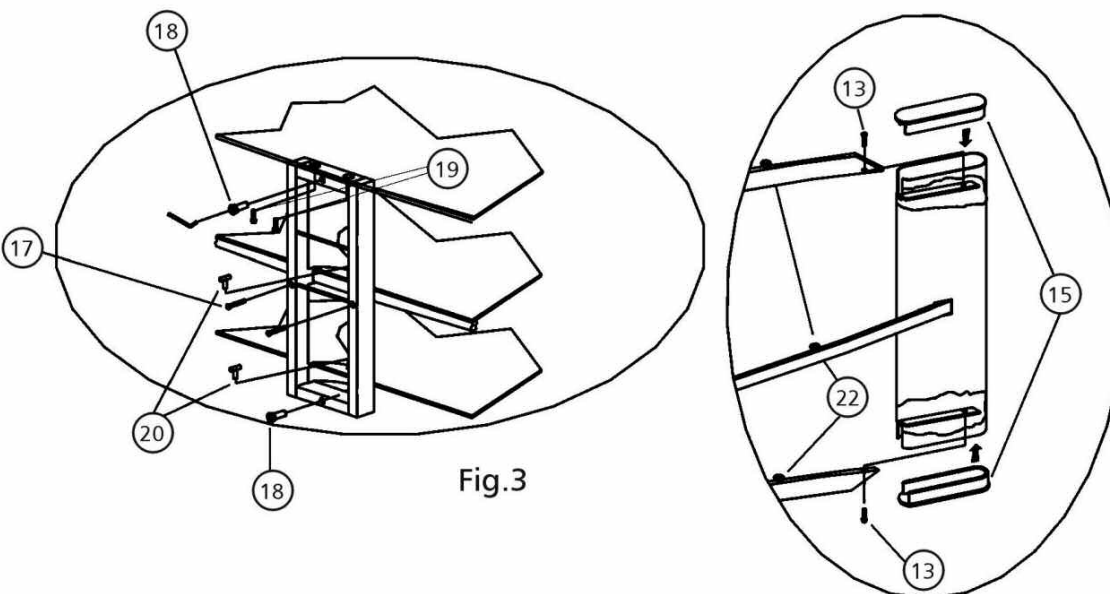

Fig. 3

Fig. 2